

APPLICATION

Palletizing:

- Cartons
- Shrink-wrapped trays
- Open trays
- Shrink-wrapped PET bottles
- Bags

De-Palletizing:

- Beverage or food cans
- Empty glass jars and bottles

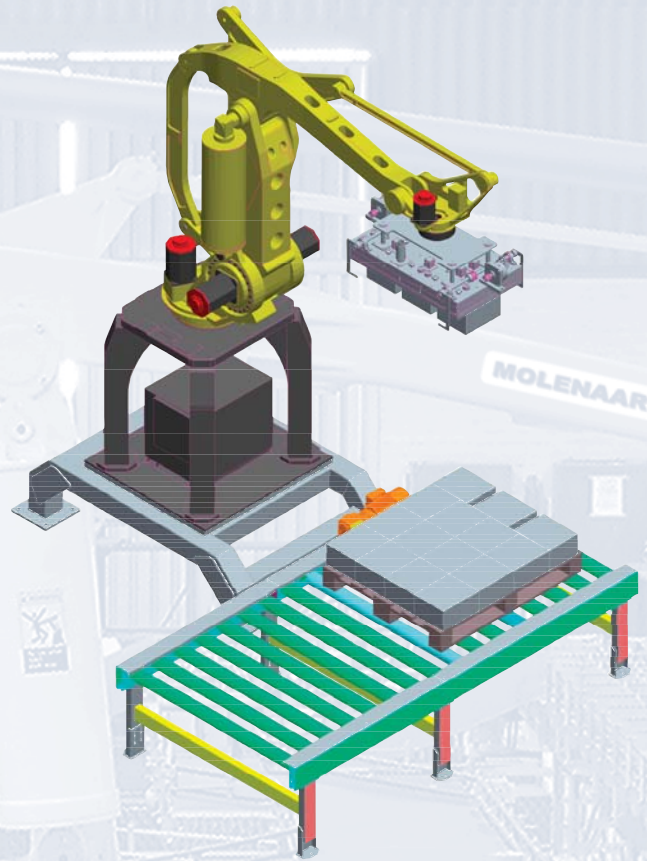

STANDARD FEATURES

- Speeds up to 5 layers per minute
- Pallet conveyors (Chain or Roller)
- PLC: Siemens or Allen Bradley
- Pneumatics: Festo
- Gear motor units: SEW
- Touch screen HMI
- Safety cage
- Forklift barriers
- Robust design
- Maintenance friendly

OPTIONS

- Intralox ARB technology for case or tray orientation
- Specialized grippers
- CE certificate

ADVANTAGES

- Low maintenance
- Customized layouts
- Flexibility to handle different package formats
- 3D Computer simulation of Robot motion



